

# HYBRID STEPPING MOTOR SPECIFICATION

DIMENSIONS unit=mm

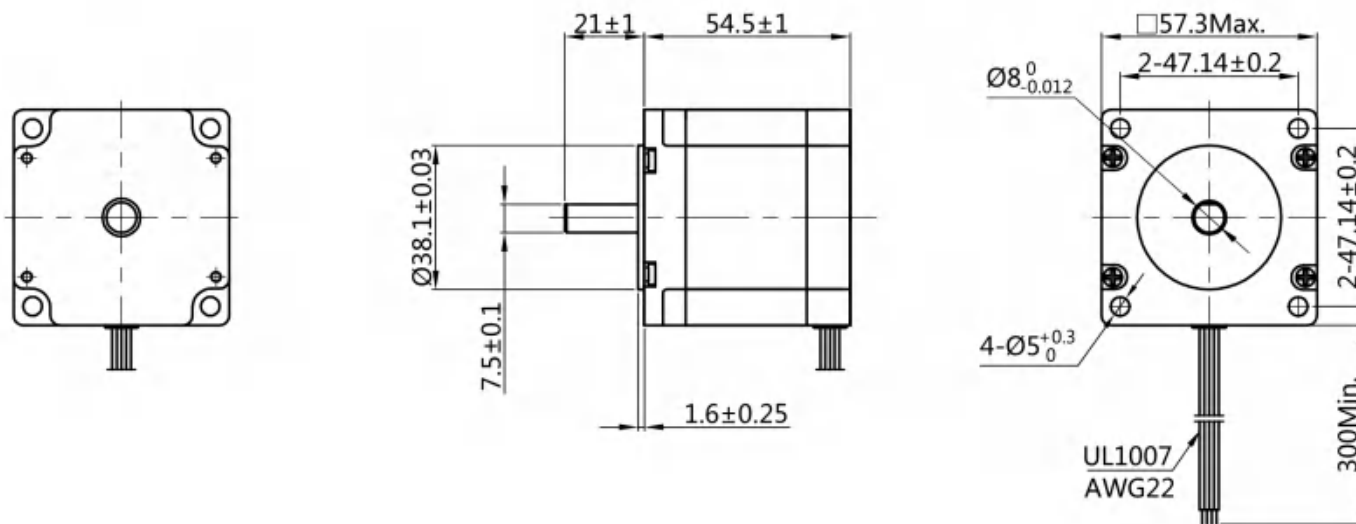

## Wiring Diagram

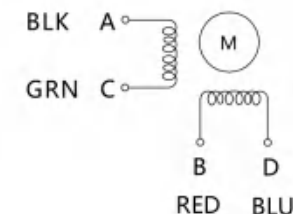

## Exciting Sequence vs. Direction of Rotation

| STEP | A | B | C | D |  |
|------|---|---|---|---|--|
| 1    | + | + | - | - |  |
| 2    | - | + | + | - |  |
| 3    | - | - | + | + |  |
| 4    | + | - | - | + |  |

Clockwise view from mounting side

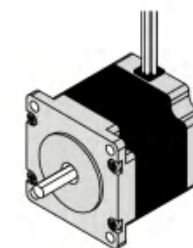

|                        |                         |                |  |  |  |
|------------------------|-------------------------|----------------|--|--|--|
| 1, Number of Phase     | 2                       |                |  |  |  |
| 2, Step Angle          | 1.8° deg.               |                |  |  |  |
| 3, Rated Voltage       | 2.5 V                   |                |  |  |  |
| 4, Rated Current/Phase | 2.8 A ( Peak Value )    |                |  |  |  |
| 5, Phase Resistance    | 0.9 Ω±0.1(20°C)         |                |  |  |  |
| 6, Phase Inductance    | 2.5 mH±20%(1kHz 1V RMS) |                |  |  |  |
| 7, Holding Torque      | 12.6 Kg.cm              |                |  |  |  |
| 8, Insulation Class    | B ( 130° ); 80K Max.    |                |  |  |  |
| 9, Weight              | 0.7 kg                  |                |  |  |  |
| <b>Specifications</b>  |                         | <b>Comment</b> |  |  |  |

| REV.       | REVISION RECORD |            | DATE |
|------------|-----------------|------------|------|
| DESIGN     | YY              | 2020.06.29 |      |
| STANDARD   |                 |            |      |
| TECHNOLOGY |                 |            |      |
| CHECK      |                 |            |      |
| APPROVE    |                 |            |      |

Changzhou BesFoc Motor Co., Ltd  
www.besfoc.com

**Specification**

|          |                  |       |     |              |
|----------|------------------|-------|-----|--------------|
| TITLE    | STEPPING MOTOR   |       |     |              |
| DWG.NO.  | BF57HS56-2804-13 |       |     |              |
| MATERIAL | ECN SIGN         | SIZE  | A4  |              |
| REV.     | A                | SCALE | 1:2 | SHEET 1 of 1 |