

Dimension:  
Unit=mm

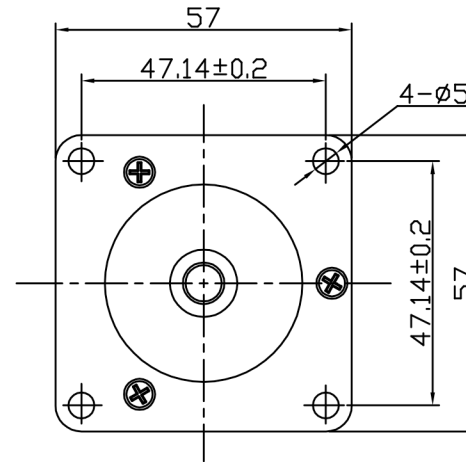
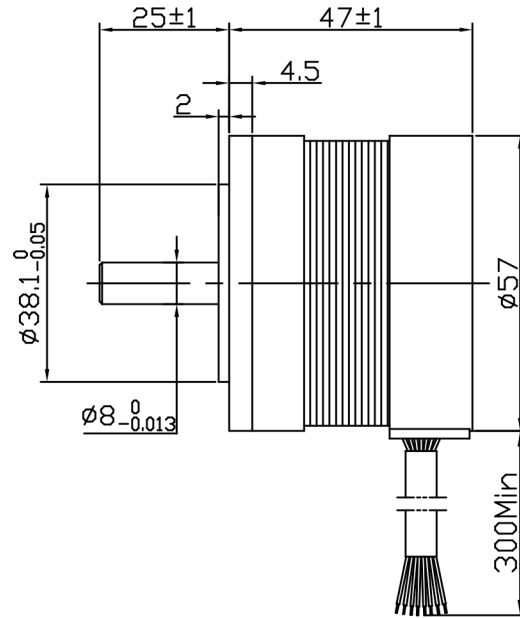

ROTATION: CCW SEE FROM LEAD END

MANUFACTUER MODEL	JK57BLF01
NUMBER OF POLES	4
PHASE TO PHASE RESISTANCE	2.2 ΩHMS
NOMINAL VOLTAGE	36 VDC
NO LOAD SPEED	4800±10% RPM
NO LOAD CURRENT	0.35 Amps Max.
RATED TORQUE	0.11 N-m
RATED SPEED	4000±10% RPM
OUTPUT POWER	46 W
BACK EMF CONSTANT	7.5 V/kRPM
TORQUE CONSTANT	0.072 N-m/A
INSULATION CLASS	B

ELECTRICAL CONNECTION TABLE

+5V	RED	红	UL1007 26AWG
HALL U	YEL	黄	
HALL V	GRE	绿	
HALL W	BLU	蓝	
GND	GND	黑	UL1007 20AWG
PHASE U	YEL	黄	
PHASE V	GRE	绿	
PHASE W	BLU	蓝	

Connection diagram:

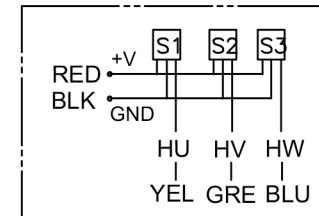

Hall sensor cable  
Note: hall sensor power supply  
voltage +5 to +20VDC

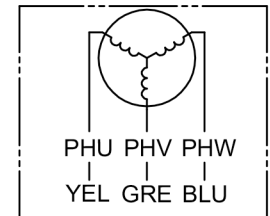

Wiring cable

					Title:			Changzhou BesFoc Motor Co., Ltd	
					Specification				
REV.	QTY.	No.	SIG.	DATE	CLS.MAK		WEIGHT	SCALE	BF57BLF01
DESIGN	CCY	19.01.03	STD.						
CHECK					PAGE:		1/1		www.besfoc.com
PROC.					APPR.				