

# 混合式步进电机规格书

## HYBRID STEPPING MOTOR SPECIFICATION

外形图 (DIMENSIONS) unit=mm

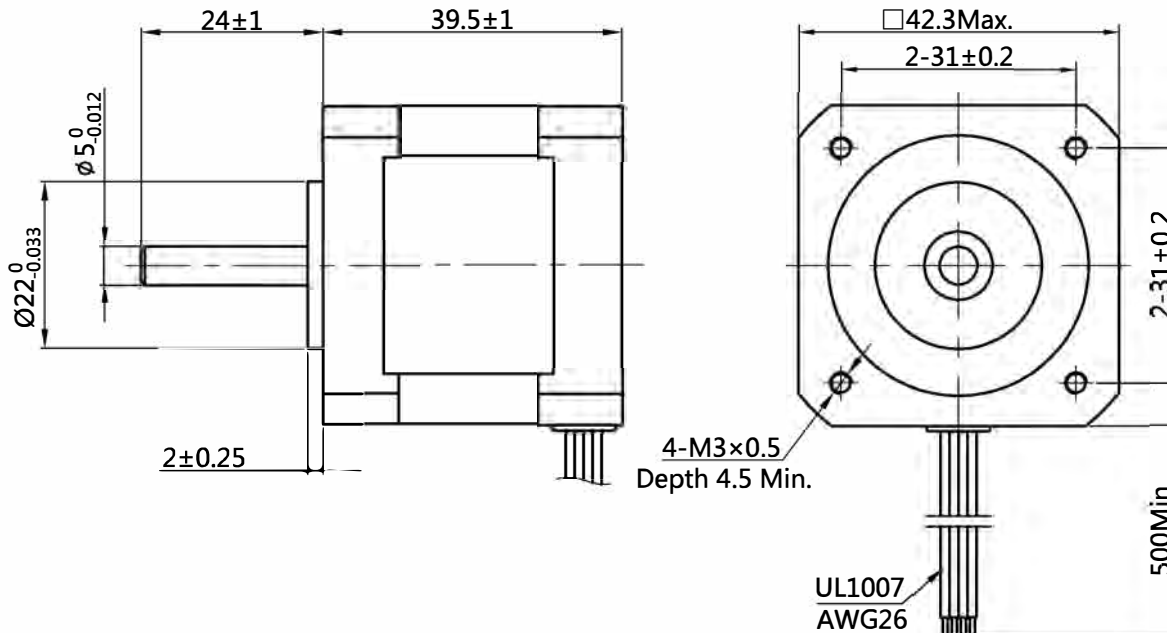

电气原理图

Wiring Diagram

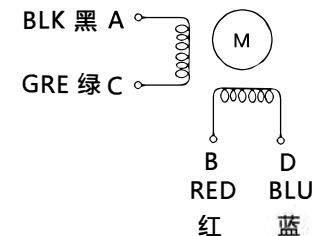

励磁顺序vs.旋转方向

Exciting Sequence vs. Direction of Rotation

STEP	A	B	C	D	
1	+	+	-	-	CCW
2	-	+	+	-	
3	-	-	+	+	
4	+	-	-	+	CW

从安装面看为顺时针方向

Clockwise view from mounting side



1、相数 Number of Phase	2				
2、步距角 Step Angle	1.8° deg.				
3、额定电压 Rated Voltage	2.55 V				
4、额定电流/相 Rated Current/Phase	1.7 A (峰值 Peak Value)				Email: sales@besfoc.com
5、相电阻 Phase Resistance	1.5 Ω±10%(20°C)				版本 REV.
6、相电感 Phase Inductance	2.3 mH±20%(1kHz 1V RMS)				设计 DESIGN 成兆茹
7、保持力矩 Holding Torque	4.2 kg.cm				Changzhou BesFoc Motor Co., Ltd
8、绝缘等级 Insulation Class	B (130°);温升 80K Max.				www.besfoc.com
9、重量 Weight	0.24 kg				规格书 Specification
规格 Specifications		备注 Comment		批准 APPROVE	

品名 TITLE	步进电机 STEPPING MOTOR		
图号 DWG.NO.	BF42HS40-1704		
材料 MATERIAL		SIZE	A4
版本 REV.	A	比例 SCALE	1:1 页 SHEET 1 of 1