

HYBRID STEPPING MOTOR SPECIFICATION

DIMENSIONS unit=mm

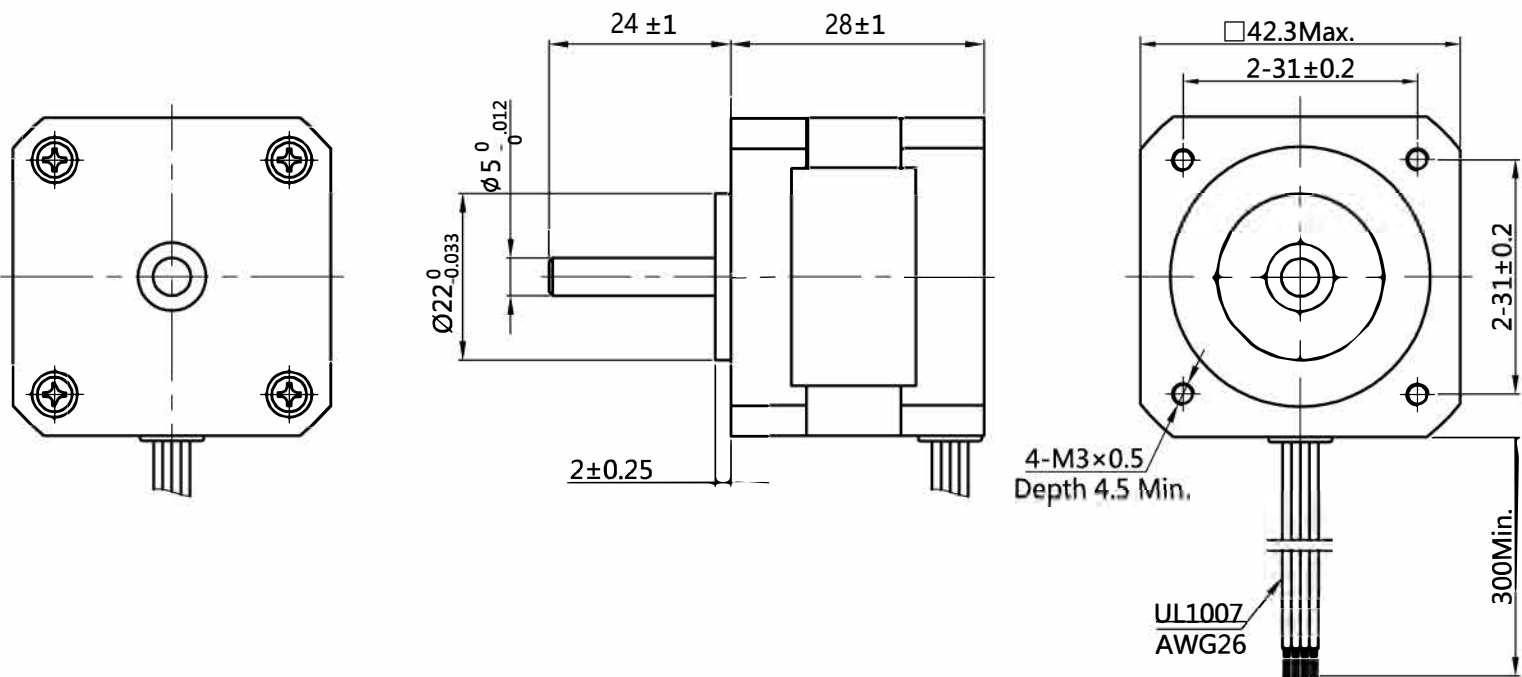

Wiring Diagram

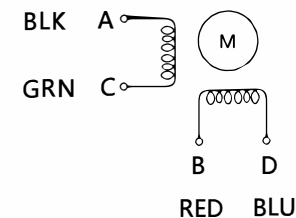

Exciting Sequence vs. Direction of Rotation

STEP	A	B	C	D	
1	+	+	-	-	CCW ↑
2	-	+	+	-	
3	-	-	+	+	
4	+	-	-	+	

CW ↓

Clockwise view from mounting side



1、 Number of Phase	2			
2、 Step Angle	1.8° deg.			
3、 Rated Voltage	/			
4、 Rated Current/Phase	0.5 A (峰值 Peak Value)			
5、 Phase Resistance	20 Ω±10%(20°C)			
6、 Phase Inductance	21 mH±20%(1kHz 1V RMS)			
7、 Holding Torque	1.8 kg.cm			
8、 Insulation Class	B (130°) ; 温升 80K Max.			
9、 Weight	0.22 kg			
Specifications	Comment			

Email: sales@besfoc.com

REV.	REVISION RECORD	DATE
	DESIGN 成兆茹 2020.6.29	Changzhou BesFoc Motor Co., Ltd
	STANDARD	www.besfoc.com
	TECHNOLOGY	
	CHECK	
	APPROVE	

Specification

TITLE	STEPPING MOTOR			
DWG.NO.	BF42HS28-0504			
MATERIAL	ECN SIGN	※	SIZE	A4
REV.	A	SCALE	1:2	SHEET 1 of 1